

Alibre Design - Part Modeling Tutorial 1

Introduction

This tutorial guides you through the creation of your first part using Alibre Design. It is assumed that you have already read *Alibre Design - Modeling Fundamentals* before starting this tutorial.

You will be creating this simple part:

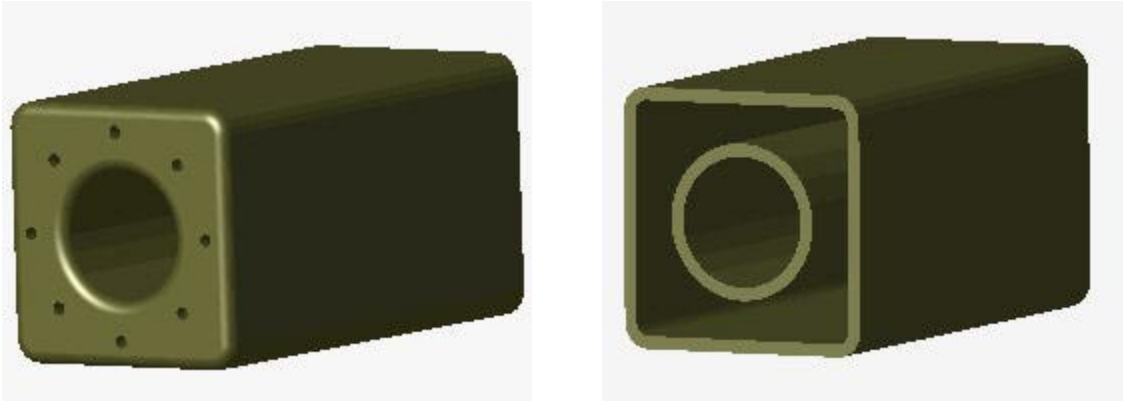

Enclosure

This tutorial will cover:

- Opening new part workspaces.
- Setting workspace properties.
- Creating sketches.
- Creating a base feature with a boss.
- Creating a hole feature.
- Creating a fillet feature.
- Creating a shell feature.
- Creating a feature pattern.
- Modifying sketches and feature properties.
- Modifying part color properties.
- Saving parts to the Repository.

Starting Alibre Design

- 1** From the Windows **Start** menu, click **Programs, Alibre Design**.

The **Alibre Design Launcher** window appears.

- 2** Click either **Work Offline** or **Connect Now** to launch Alibre Design; sign on if you want to work online. You can complete this tutorial working offline or online.

The Alibre Design Home window appears.

Opening a New Part Workspace

- 1 To open a new part workspace, on the Home window, from the **File** menu, select **New > Part**, or click the **New Part**  icon on the main toolbar.

A new part workspace appears.

Setting the Workspace Properties

Before you begin, set the following workspace and design properties. These specific options are not required, but may make sketching and modeling tasks easier to learn.

Design Options

- 1 In the part workspace, from the **Tools** menu, select **Options**.

The **Options** dialog box appears.

- 2 Click the **General** tab if it is not already selected.
- 3 In the **Design** options list, select the following options:

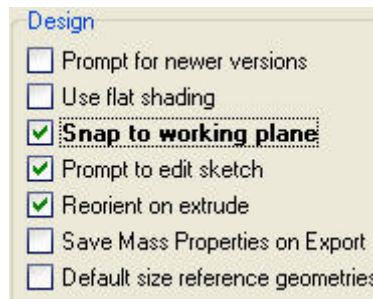

- 4 Next, click the **Grid** tab, and unselect the **Display Grid** and **Snap to Grid** options.
- 5 Click **OK** to apply the settings and close the Options dialog box.

Units and Dimensions

- 1 In the part workspace, from the **File** menu, select **Properties**.

The **Design Properties** dialog box appears.

- 2 Click the **Units** tab if it is not already selected.
- 3 In the **Display Units** area, make sure that:
 - **Units** is set to **Inches**
 - **Format** is set to **Decimals**
 - **Precision** is set to **3**
- 4 Also, click the **Show Units for Dimensions** box. All other settings and default values in the Units tab are acceptable for this tutorial.

- 5 Next, click the **Dimensions** tab.
- 6 Check the **Show Equations** option. All other settings and default values in the Dimensions tab are acceptable for this tutorial.
- 7 Click **Apply**.
- 8 Click **Close**.

Modeling the Enclosure

Sketching a Rectangle



The first feature in the design is known as the base feature. The base feature in this part is a rectangular extrusion created from a square profile. Begin by sketching a rectangle.

- 1 Before you begin sketching, first select the **XY-Plane** to set it as the working plane. To select the XY-Plane, click the **Select**  tool on the View toolbar and then click **XY-Plane** in the Design Explorer on the left side of the workspace, or click on the XY-Plane in the work area.

The XY-Plane turns yellow after you select it (The colors described in this tutorial are based on using the **Dark Background** color scheme. To change the color scheme, from the **Tools** menu, select **Options**, then the **Color Scheme** tab).

Note: When you move your cursor over an icon in a toolbar, a label displays the tool name.



- 2 To enter sketch mode, select the **Sketch Mode**  tool on the Sketching toolbar. The work area view reorients so that the XY-plane is parallel to the screen.
- 3 Select the **Rectangle by Two Corners**  tool on the Sketching toolbar. The cursor changes to .
- 4 Click once in the upper left quadrant of the working plane to start sketching the rectangle. (Most sketching operations are performed through a series of mouse clicks and cursor movements; typically, click and release to initiate an operation, move the cursor to size or position, and click and release again to complete the operation).

Note: Hints are displayed in the lower left corner of the workspace and describe how to start or complete an operation. For example, you will see "**Pick start point**" and "**Pick the point for the width and height. ESC to quit**" as you sketch the rectangle.

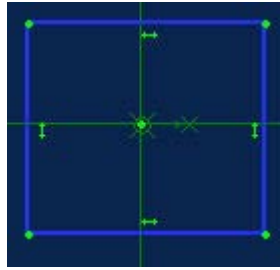

- 5 Move the cursor to the lower right quadrant of the working plane. You will see a preview rectangle as you move the cursor.
- 6 Click again in the lower right quadrant of the working plane to complete the rectangle. The resultant sketch contains blue sketch figures (e.g. lines), green sketch nodes (e.g. end points), and green constraint symbols.



Note: If you make a mistake while sketching, you can use the **Undo** tool  on the Main toolbar, or from the **Edit** menu, select **Undo**, to undo the last operation.

Placing Dimensions on the Rectangle

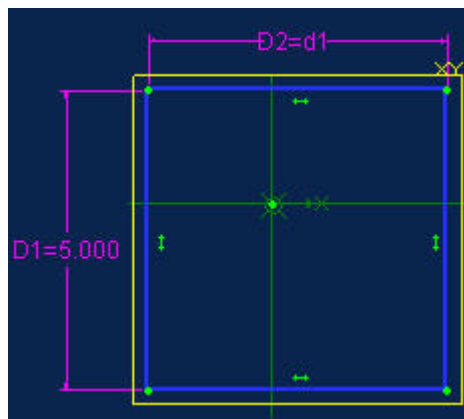

Now specify the size of the sketched rectangle by adding dimensions.

- 1 Select the **Dimension**  tool on the Sketching toolbar, or from the **Sketch** menu, select **Dimension**. The cursor changes to .
- 2 Move the cursor over the left vertical line of the rectangle, the line turns red.
- 3 Click once on the line, a dimension appears.
- 4 Move the dimension to the left of the vertical sketch line.
- 5 Click once to place the dimension. The dimension control box appears. Enter a value of **5.0** in the box and press **Enter**.
- 6 The dimension is displayed.
- 7 Move the cursor over the top horizontal line of the rectangle, the line turns red.
- 8 Click once on the top horizontal line, a dimension appears.
- 9 Move the dimension to the top of the horizontal line.
- 10 Click to place the dimension. The dimension control box appears. Enter **D1** in the box and press **Enter**. By entering D1, you are ensuring that the length of this line will always be equal to the length of the first vertical line you dimensioned. If you change the value of D1, D2 will automatically change.





Applying Manual Constraints on the Sketch

Center the sketch about the origin by manually placing constraints on the sketch.

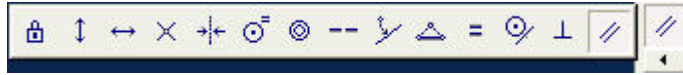

- 1 On the Sketching toolbar, click the small black arrow  under the **Parallel Constraint**  tool; the constraint toolbar appears.



- 2 Select the **Symmetric Constraint**  tool from the constraint toolbar. The cursor changes to .
- 3 To apply the first constraint, click the **Y-Axis** in the work area or the Design Explorer, a green reference line appears on the axis.
- 4 Click the **left** vertical line, the line turns yellow.
- 5 Click the **right** vertical line. The vertical lines are now constrained symmetrically about the Y-Axis and two symmetric constraint symbols appear.
- 6 To apply the second constraint, click the **X-Axis** in the work area or the Design Explorer, a green reference line appears on the axis.
- 7 Click the **top** horizontal line, the line turns yellow.
- 8 Click the **bottom** horizontal line. The horizontal lines are now constrained symmetrically about the X-Axis and two additional symmetric constraint symbols appear.

Sketching a Circle

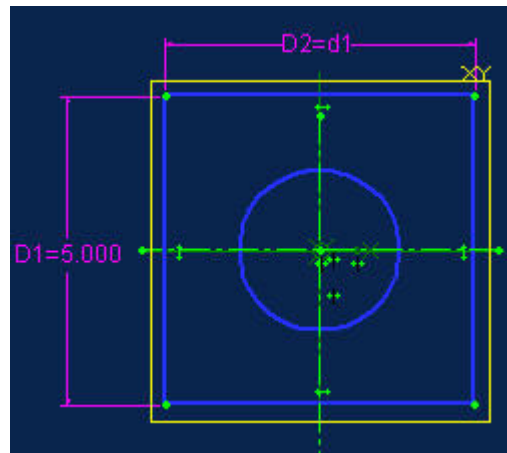

Next, sketch a circle within the existing square.

- 1 Click the **Circle**  tool on the Sketching toolbar. The cursor changes to .
- 2 Move the cursor over the origin. The origin turns red and the cursor changes to .
- 3 Click to place the center of the circle at the origin.
- 4 Move the cursor away from the origin; you will see a blue preview circle as you move the cursor.
- 5 Click to place the edge of the circle within the original square sketch.





Placing a Dimension on the Circle

Place a dimension on the circle to define its size.

- 1 Click the **Dimension**  tool on the Sketching toolbar, or from the **Sketch** menu, select **Dimension**. The cursor changes to .
- 2 Click the circle, a diameter dimension appears.
- 3 Move the dimension away from the circle.
- 4 Click to place the dimension, the dimension control box appears.
- 5 Enter a value of **2.5** in the box and press **Enter**.

Adding Fillets to the Sketch

Now finish the sketch by placing fillets on the four corners of the square.

- 1 Click the **Fillet**  tool on the Sketching toolbar, or from the **Sketch** menu, select **Fillet**.
The **Fillet Figures** dialog box appears and the cursor changes to .
- 2 Click the left vertical line; the line turns yellow and is listed in the **Figures to Fillet** area in the dialog box.
- 3 Hold the **Shift** key and click the top horizontal line. The line turns yellow and is listed in the **Figures to Fillet** area in the dialog box.

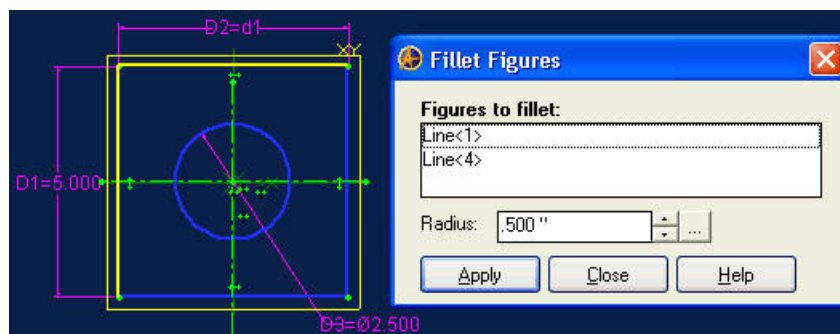

4 Change the **Radius** value to **.500"** if it is not already set.



5 Click **Apply** to create the fillet but do not close the dialog box.

The fillet appears with a .500" radius.

6 Repeat steps 2-5 to place fillets on the remaining three corners of the square. Remember to hold the **Shift** key as you select the second line.

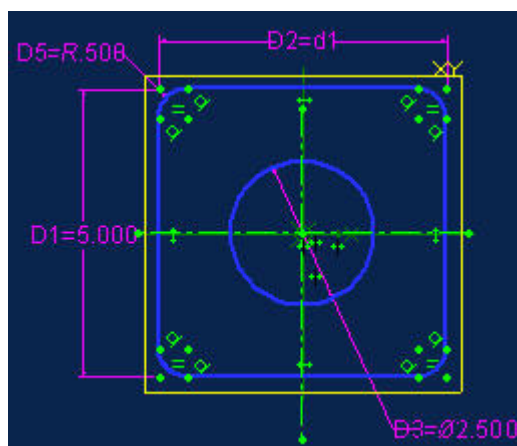
7 Click **Close** on the Fillet Figures dialog box when finished. The sketch is now complete.



8 To exit sketch mode, click the **Sketch Mode**  tool on the Sketching toolbar, or click the **Select**  tool on the View toolbar. The sketch changes from blue to yellow, and the dimensions and green nodes and constraint symbols are no longer visible.

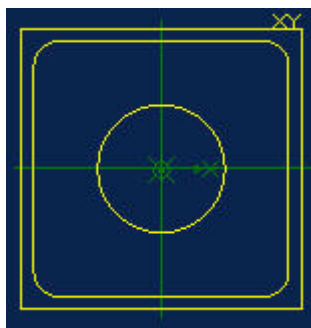

- 9 After you exit sketch mode, the completed sketch is listed in the Design Explorer as **Sketch<1>** under the **Features** node.

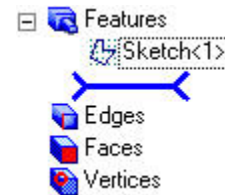

Note: You can edit sketches at anytime. To edit a sketch, double-click the sketch in the Design Explorer, or right-click the sketch and select **Edit** from the pop up menu.

Creating the Base Feature

The first feature in any part is called the base feature. Create the base feature in this part by extruding the sketch created in the steps above.

- 1 To create the base feature, click **Sketch<1>** in the Design Explorer.
- 2 Select the **Extrude Boss**  tool on the Part Modeling toolbar, or from the **Feature** menu, select **Boss > Extrude**.

The Extrude Boss dialog box appears and the view changes to isometric displaying a preview of the extrusion.

- 3 Under **Type**, select **Mid-Plane**.
- 4 Change the length value to **10"**.
- 5 Click **OK** to create the extrusion. The extrusion appears.
- 6 If you need to zoom out to see the entire model, click the **Zoom to Fit**  tool on the View toolbar.
- 7 The new feature is listed in the Design Explorer as **Extrusion<1>** under the **Features** node. **Sketch<1>**, which you used to create the feature, is now listed under **Extrusion<1>**.

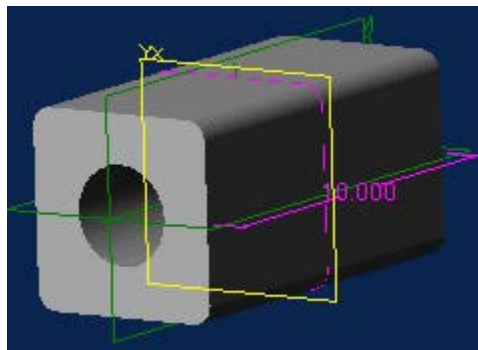
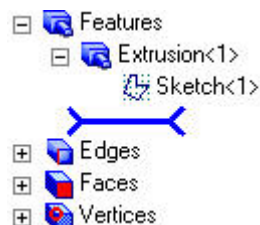

Note: You can edit the properties of a feature (e.g. type, length, etc.). Right click on the feature in the Design Explorer and select **Edit** from the pop up menu.

Saving the Part

Save the work you have completed up to this point.

- 1 Click **Save**  on the Standard toolbar, or from the **File** menu, select **Save**.

The **Save** dialog box appears.

- 2 Click your local repository.

Note: You save, manage, and share files using the repository system. Local repositories reside on your system's hard drive. Repositories can also be created remotely on other hard drives you have access to on your network. Learn more about repositories in the Alibre Design Help under *Data Sharing and Management*.

- 3 Click **New Folder**, the New Folder dialog box appears.

- 4 Type **Tutorial** in the New Folder dialog box.

- 5 Click **OK** to create the Tutorial folder.

- 6 Click the **Tutorial** folder.

- 7 In the **Name** text box, type **Enclosure**.

- 8 In the **Save as type** list, select **Alibre**.

- 9 Check **Make new versions for all** if it is not already selected.

- 10 Click **Save**. The Enclosure part is now saved in your local repository.

Adding a Shell Feature

After the base feature has been created, you can add more features to the part. In this section you will add a shell feature which removes material from a selected face, leaving a thin-walled part.

- 1 Click the **Select**  tool on the View toolbar, if it is not already selected.

- 2 Move the cursor over the face on either end of the extrusion. Since the part is symmetric, it does not matter which end you use.

The face turns red when your cursor is over it, and the cursor changes to show that it is over a face.

- 3 Click the face to select it, the face turns yellow.

- 4 Click the **Shell**  tool on the Part Modeling toolbar, or from the **Feature** menu, select **Shell**.

- 5 The Shell dialog box appears, and the **Faces to remove** area is populated with the face you selected.



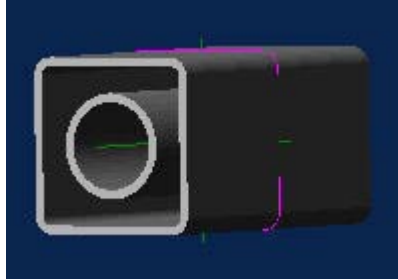

- 6 Change the **Standard thickness** value to **.25"**.
- 7 Click **OK** to create the shell feature.
- 8 The new feature is listed in the Design Explorer as **Shell<2>** under the **Features** node.



Adding a Fillet Feature

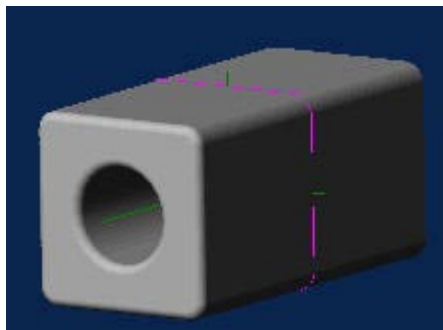

Add a fillet feature to the other end face. The fillet feature will remove or round all the sharp edges associated with the face.

- 1 Click the **Select**  tool on the View toolbar, if it is not already selected.
- 2 Rotate the view so that the opposite end of the extrusion is visible. To rotate, press both left and right mouse buttons and drag the cursor.
- 3 Select the end face on the extrusion, the face turns yellow.
- 4 Select the **Fillet**  tool on the Part Modeling toolbar, or from the **Feature** menu, select **Fillet**.
- 5 The **Fillet Edges** dialog box appears, and the **Entities to fillet** area is populated with the face you selected.
- 6 Change the **Radius** value to **.5"** if it is not already set.
- 7 Click **OK** to create the fillet feature.
- 8 The new feature is listed in the Design Explorer as **Fillet<3>** under the **Features** node.



Adding a Hole Feature

Continue to define the shape of the part by adding a hole feature.

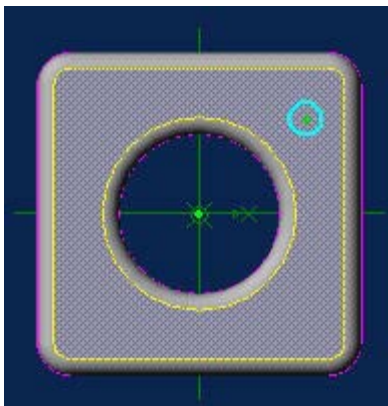

- 1 Click the **Select**  tool on the View toolbar, if it is not already selected.
- 2 Move the cursor over the end face that you used to create the fillet feature.
- 3 Click the face to select it, the face turns yellow.
- 4 Click the **Hole**  tool on the Part Modeling toolbar, or from the **Feature** menu, select **Hole**.
- 5 The view reorients so that it is parallel to the screen, and a blue preview hole is displayed near the location you clicked on the selected face.





The Hole Dialog box also appears, and the **Start surface** area is populated with the face you selected. Drag the Hole Dialog box out of the way so it does not obscure the work area but do not close it.

- 6 Place the center of the hole on the **X-Axis** by placing a coincident constraint on the sketch. On the Sketching toolbar, click the small black arrow , the constraint toolbar appears.

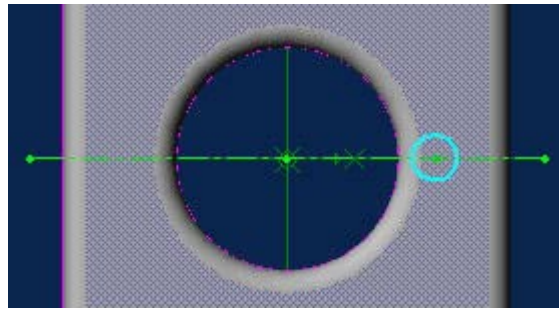

- 7 Click the **Coincident Constraint**  tool on the constraint toolbar. The cursor changes to  to .
- 8 To place the coincident constraint, move the cursor over the **X-Axis** and click, or click **X-Axis** in the Design Explorer, the X-Axis turns blue.
- 9 Move the cursor over the green center node in the blue preview circle; the node turns red when the cursor is over it.
- 10 Click the center node of the blue preview circle; the blue preview circle moves and is now constrained to the X-Axis.



- 11 To position the hole with respect to the origin, select the **Dimension**  tool on the Sketching toolbar, or from the **Sketch** menu, select **Dimension**. The cursor changes to .
- 12 Select the **Y-Axis**, a dimension appears.
- 13 Move the cursor over the green center node of the blue preview circle, the node turns red.
- 14 Click the center node of the blue preview circle, a horizontal dimension between the Y-Axis and the center node appears.
- 15 Move the dimension to a more visible area if necessary.
- 16 Click to place the dimension, the dimension control box appears.
- 17 Enter **1.875** in the control box and press **Enter**.
- 18 The hole is now properly positioned with respect to the origin.
- 19 In the Hole dialog box, under **Type**, select **Simple**.
- 20 Under **Depth Condition**, select **Through All**.
- 21 Change the Diameter value to **.250"**.
- 22 Click **OK** to create the hole feature.
- 23 The new feature is listed in the Design Explorer as **Hole<4>** under the **Features** node.

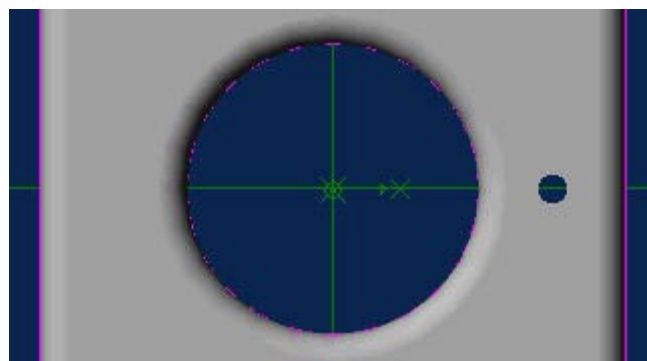

Creating a Pattern of the Hole Feature

Next, create a circular feature pattern of the hole about the origin.

- 1 Click **Hole<4>** in the Design Explorer to select it.
- 2 From the **Feature** menu, select **Pattern > Circular**.
The **Circular Pattern** dialog box appears and the **Select Objects** area is populated with Hole<4>.
- 3 Click **Circular Path Center** in the dialog box. The title appears in bold.
- 4 Select the **Z-Axis** in the work area or the Design Explorer.
Z-Axis appears in the **Circular Path Center** area.
- 5 Change the **Copies** value to **8**.
- 6 Change the **Angle** value to **45°**. Blue preview circles appear showing the location of the patterned holes.
- 7 Click **OK** to create the circular pattern.
- 8 The new feature is listed in the Design Explorer as **Pattern<5>** under the **Features** node.

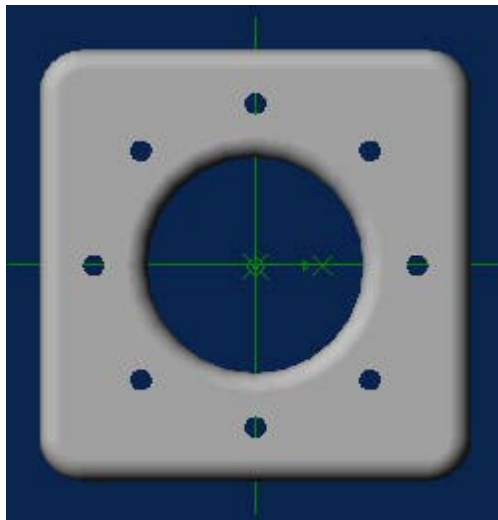

Changing the Part Color Properties

Finish the part by adding color properties.

- 1 From the **Edit** menu, select **Color Properties**, or right click in the work area and select **Color Properties** from the pop up menu.

The Color Properties dialog box appears.

- 2 Click the **Color** button.

The Color palette appears.

- 3 Select a color by clicking a **Basic Color**, or create a custom color.

- 4 Click **OK**.

- 5 Slide the **Opacity** and **Reflectivity** controls to make the part semi-transparent and/or reflective.

- 6 Click **OK** to apply the settings.

- 7 Click  on the Standard toolbar, or from the **File** menu, select **Save**.

The Save dialog box appears.

- 8 Click **Save**.

Additional Tasks

The true benefits of parametric solid modeling are realized when changes or modifications to a part are required. The steps below provide examples of how quickly and efficiently a part can be changed.

Editing an Existing Sketch

In the first section of this tutorial, you created a sketch that defined the profile of the Enclosure part. You now edit the sketch and modify a dimension.

- 1 In the Design Explorer, under the **Features** node, click the plus sign next to **Extrusion<1>** if it is not already expanded.
- 2 To edit the sketch, double click **Sketch<1>**, or right click on **Sketch<1>** and select **Edit** from the pop up menu.
- 3 The view reorients so that it is parallel to the screen, and you are now in sketch mode.

You may need to zoom out to see all the dimensions associated with the sketch. If you have a mouse wheel, use it to zoom out. If not, click the **Zoom Mode**  tool on the View toolbar and zoom out until all the dimensions are displayed.

- 4 Click the **Select**  tool on the Sketching toolbar.
- 5 Move the mouse over any part of the **D1** dimension, the dimension turns red.
- 6 Double click on the **D1** dimension, the dimension control box appears.
- 7 Change the value in the dimension control box to **6.25** and press **Enter**.

The sketch changes size but the part shape does not change.

- 8 Update the part by exiting sketch mode. Click the **Select**  tool from the View toolbar.
The part is regenerated and reflects the changes made to the sketch.

Reordering Features Using the Design Explorer

You can also quickly alter a part by changing the order in which features are generated.

- 1 After completing the Enclosure part, the **Features** node in the Design Explorer lists five features.

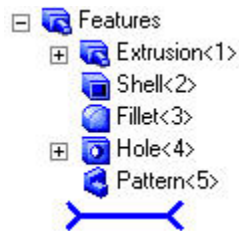

- 2 Click **Fillet<3>** and hold the mouse button down.
- 3 While holding the mouse button down, move the cursor up the **Features** tree. The cursor changes.



- 4 Release the mouse button when the cursor is over **Extrusion<1>**.
- 5 The Features order changes, **Fillet<3>** is now listed before **Shell<2>**.

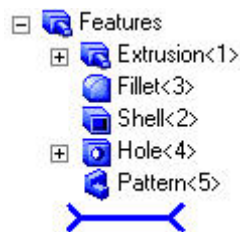

The change is slight, but notice on the part that a fillet has been created on the interior edges at the bottom of the Enclosure. This occurs because Fillet<3> is now generated before Shell<2>, and the fillet radius exceeds the shell wall thickness.

This completes *Part Modeling Tutorial 1*. You do not need to save the changes made in the **Editing a Sketch** and **Reordering Features** sections. The Enclosure part will continue to be used in additional tutorials.

Providing Feedback Related to this Tutorial

Alibre, Inc. is committed to providing the highest quality documentation, and we welcome your feedback. Please email us if you have comments or suggestions about this tutorial.

Please include the following information with your feedback:

- 1** Topic title
- 2** Page number
- 3** Brief description of content (for example, inaccuracies in step-by-step instructions, grammatical errors, information that requires further clarification or additional details, etc.)
- 4** Your suggestion for improving/correcting the documentation

Please direct your email message to:

userexperience@alibre.com